

DDF6-A

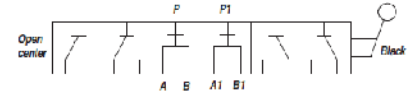
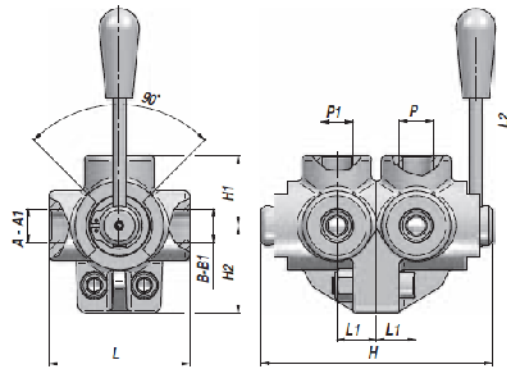
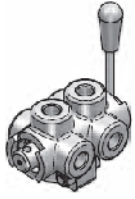

Code Code Código	P A - B BSP	P1 A1 - B1 BSP	Q MAX l/min	P MAX bar	Type Type Tipo	L	L1	L2	H	H1	H2	kg
V70667.A00600	3/8"	3/8"	60	315	DDF6-A 020	73	21	135	124	36,5	42	1,76
V70667.A00800	1/2"	1/2"	90	280	DDF6-A 030	85	24	130	140	42,5	53	2,90
V70667.A01200	3/4"	3/4"	120	250	DDF6-A 040	91	28	130	160	45,5	56	3,74
V70667.A01600	1"	1"	180	220	DDF6-A 050	98	31,5	160	180	49	64	5,20

MONTAGE EN LIGNE
LINE MOUNTING
MONTAJE EN LINEA

MATERIEL - MATERIAL: FONTE - CAST IRON - HIERRO FUNDIDO

DEVIATEUR A 6 VOIES - CENTRE FERME
6-WAY FLOW DEFLECT VALVE - CLOSED CENTRE
VALVULA DESVIADORA DE 6 VIAS - CENTRO CERRADO

DDF6-C

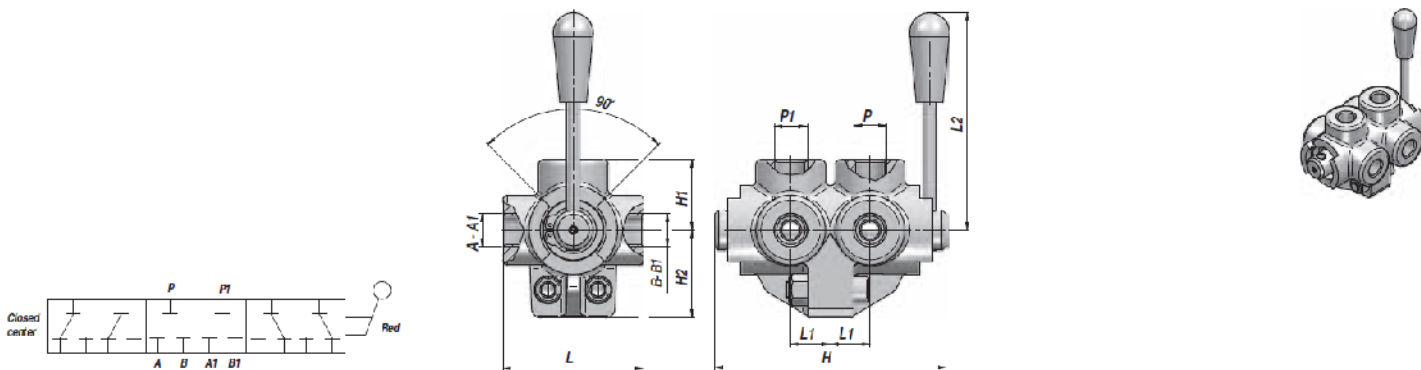

Code Code Código	P A - B BSP	P1 A1 - B1 BSP	Q MAX l/min	P MAX bar	Type Type Tipo	L	L1	L2	H	H1	H2	kg
V70667.C00600	3/8"	3/8"	60	315	DDF6-C 020	73	21	135	124	36,5	42	1,76
V70667.C00800	1/2"	1/2"	90	280	DDF6-C 030	85	24	130	140	42,5	53	2,90
V70667.C01200	3/4"	3/4"	120	250	DDF6-C 040	91	28	130	160	45,5	56	3,74
V70667.C01600	1"	1"	180	220	DDF6-C 050	98	31,5	160	180	49	64	5,20

MONTAGE EN LIGNE
LINE MOUNTING
MONTAJE EN LINEA

MATERIEL - MATERIAL: FONTE - CAST IRON - HIERRO FUNDIDO

DDF 6 V

DISTRIBUTORE DI FLUSSO A 6 VIE

6 WAY FLOW DIVERTER

APPLICAZIONE

La singola sezione permette di collegare o escludere il flusso verso due utilizzi usando una sola alimentazione. Una sola leva, tramite un accoppiamento meccanico, aziona due sezioni contemporaneamente. Questa particolare configurazione si presta anche per l'azionamento di due attuatori semplice effetto.

MONTAGGIO

Collegare le alimentazioni alle bocche P e P1 e gli utilizzi rispettivamente alle bocche A, B e A1, B1.

FUNZIONAMENTO

Ruotando la leva in pos.1 si alimentano le bocche A e A1.

Ruotando la leva in pos.2 si alimentano le bocche B e B1.

Tipo C (centro chiuso): con la leva in posizione centrale le bocche P, A, B e P1, A1, B1 sono tutte chiuse (ammesso trafilamento contenuto).

Tipo A (centro aperto): con la leva in posizione centrale ogni sezione ha le bocche collegate.

A RICHIESTA

Corpo cromato - Corpo zincato - Perno nichelato - Fusione con trattamento di cataforesi.

NOTE COSTRUTTIVE

Corpo in ghisa - Componenti in acciaio trattati termicamente - Trafilamento contenuto.

APPLICATION

Every single 3 way flow diverter connects or takes out inlet flow towards two ports. While turning, the handle drives two sections at the same time, by mechanical connection. This special hydraulic scheme controls single action actuators.

INSTALLATION

P And P1 ports are connected with inlet flow and A, A1 and B, B1 with actuator ports.

OPERATION

Hand lever in pos.1 allows flow towards A and A1 ports.

Hand lever in pos.2 allows flow towards B and B1 ports.

C Type (closed center): when hand lever is in the mid position all ports are closed (low leakage may occur).

A Type (open center): when hand lever is in the mid position all ports of each selection are connected.

OPTIONAL

Chromium plated body - Zinc plated body - Nickel plated spool - Cathoresis-treated casting.

FEATURES

Cast iron body - Hardened spool - Low leakage.

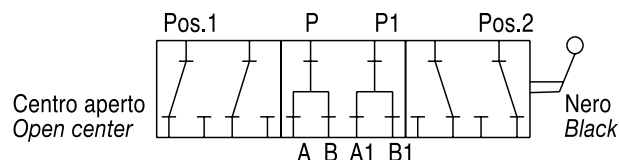
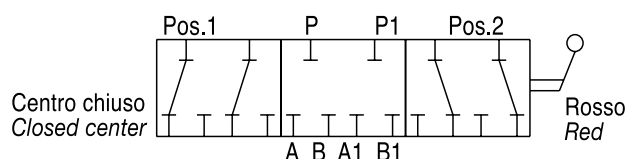

ESEMPIO D'ORDINAZIONE - ORDERING CODE EXAMPLE

Dimensione 02 - Schema con centro aperto
- Filetto 3/4-16 SAE

DDF6V 02 A S

2 Dimension - Open center
- 3/4-16 SAE Port thread

Dimensione 03 - Schema con centro chiuso
- Filetto 1/2 GAS

DDF6V 03 C

03 Dimension - Closed center
- 1/2 GAS Port thread

CODICE D'ORDINAZIONE - ORDERING CODE

DDF6V					
Dimensione/Dimension			Schema/Hydraulic Scheme		Tipo Filetto/Port Type
	GAS	NPT	SAE	A	Centro aperto Open center
02	3/8	3/8	3/4-16	C	Centro chiuso Closed center
03	1/2	1/2	7/8-14		
04	3/4	3/4	1 1/16-12		
05	1	1	1 5/16-12		
Trattamenti/Treatments					
	Fusione grezza Casting				
Z	Fusione zincata Zinc-plated casting				
ZN	Fusione zincata, perno nichelato Zinc-plated casting, nickel-plated spool				
CT	Fusione con trattamento di cataforesi Cathoresis-treated casting				

DDF 6 V

DISTRIBUTORE DI FLUSSO
A 6 VIE

6 WAY
FLOW DIVERTER

SCHEDA - CARD

B20/0

CARATTERISTICHE - HYDRAULIC FEATURES

Dimensione/Dimension		02	03	04	05
Pressione max/Max Pressure	bar	315	280	250	220
Portata max/Max Flow	l/min	60	90	120	180

N.B.: per l'utilizzo di altri parametri vogliate consultarci
Note: if application needs other/specific parameters or measures please contact us

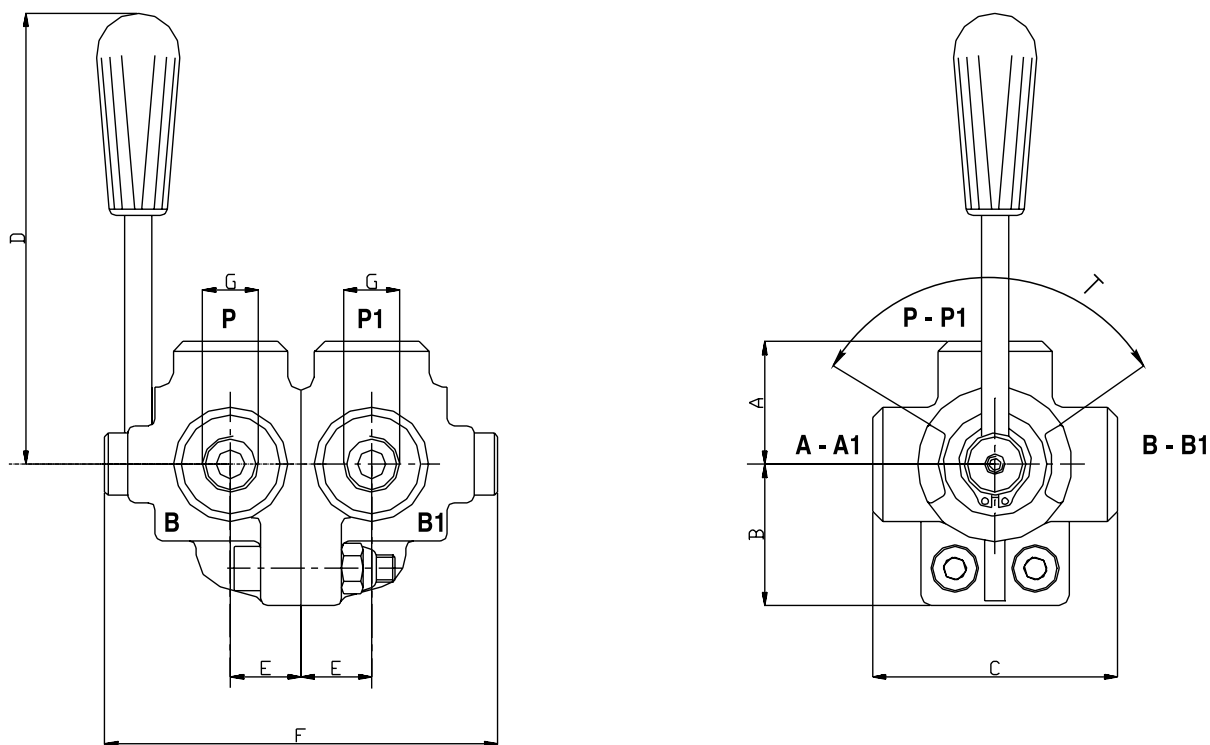

DIMENSIONI E PESI - EXTERNAL DIMENSIONS AND WEIGHTS

Dimensione/Dimension	A	B	C	D	E	F	G GAS	G NPT	G SAE	T°	Peso Weight kg
02	36,5	42	73	135	21	124	3/8	3/8	3/4-16	90	1,76
03	42,5	53	85	130	24	140	1/2	1/2	7/8-14	90	2,90
04	45,5	56	91	130	28	160	3/4	3/4	1 1/16-12	90	3,74
05	49	64	98	160	31,5	180	1	1	1 5/16-12	90	5,20